

900GDO

900mm built-in gas double oven & grill

For Natural Gas models

User & Installation Handbook

The logo consists of the word "STOVES" in a bold, white, sans-serif font, centered within a black rectangular box. This box is itself centered within a larger, white rectangular frame that has a thin black border.

STOVES

Stoves Customer Care

Thank you for choosing this British built appliance from Stoves. We hope you enjoy many years of trouble free cooking with this oven. Should you need to contact us however, please call the number below and our Customer Care Centre staff will be pleased to help in any way they can.

0871 22 22 502

When you dial this number you will hear a recorded message and be given a number of options. This indicates that your call has been accepted and is being held in a queue. Calls are answered in strict rotation as our Customer Care Representatives become available.

When calling please have to hand you appliances model an serial numbers. These numbers help us to quickly identify your product and enable our Customer Care team to provide you with the most up to date advice and support.

Alternatively spares and service call outs can be requested via our website:
www.stoves.co.uk

Outside the UK and Northern Ireland, refer to your local supplier.

If you smell gas:

Do not try to light any appliance. Do not touch any electrical switch.

Call the Gas Emergency Helpline at TRANSCO on: **0800 111999**

IMPORTANT NOTICE

Please note the cooling fan fitted to this appliance is an integral part of its safety and functionality.

When the appliance is installed care must be taken that the cooling fans performance is not impeded by any objects coming into contact with it. (Installation pipes, leads etc)

Care must also be taken that there is sufficient air flow at the rear of the appliance for the cooling fan to run at its optimum efficiency. (Particularly Built In appliances) See clearance dimensions in the installation section of the booklet.

During use the Appliance must never be disconnected from the Mains supply as this will seriously affect the safety and performance of the appliance, particularly in relation to surface temperatures becoming hot and gas operated parts not working efficiently.

The cooling fan is designed to run on after the control knob has been switched off to keep the front of the appliance and the controls cool until the appliance has naturally cooled itself.

The Gas Consumer Council (GCC) is an independent organisation which protects the interests of gas users. If you need advice, you will find the telephone number in your local telephone directory under Gas.

The appliance must be installed (and serviced) by a Corgi registered approved installer or a person competent to ensure that the installation is in accordance with "The Gas Safety (Installation and Use) Regulations 1994", and the "The Gas Safety (Installation and Use) (Amendment) Regulations". Failure to comply with these Regulations is a criminal offence.



Contents

User Section	3 - 25
Introduction	3
Be Safe - Not Sorry	6
Using the Grill	7
Using the Ovens	9
Using the Top Oven	10
Top Oven baking guide	11
Using the Main Oven	12
Main Oven baking guide	13
Roasting guide	14
Roasting Turkey	15
Traditional fruit cakes	15
Slow cooking, Frozen & Chilled food	16
Automatic cooking	17
Programmer / clock	18
Cleaning	25
Installation Instructions	28
Regulations & standards	28
Ventilation requirements	28
Step 1: Prepare installation	29
Step 2: Connect to electricity supply	31
Step 3: Connect to gas supply	32
Step 4: Check edging strip	33
Step 5: Secure appliance to housing unit	33
Step 6: Commissioning	34
Technical Data	35
Stoves Customer Care	36

Please keep this handbook for future reference, or for anyone else who may use this appliance.

Introduction

We hope that the following information will help you to familiarise yourself with the features of the appliance, and to use it successfully and safely.

Our policy is one of constant development and improvement. Strict accuracy of illustrations and specifications is not guaranteed. Modification to design and materials may be necessary subsequent to publication.

This appliance must be installed in accordance with the regulations in force and only in a well ventilated space. Read the instructions before using or installing this appliance.

Your 1st Year Guarantee

To fulfil the conditions of your guarantee, this appliance must be correctly installed and operated, in accordance with these instructions, and only be used for normal domestic purposes.

Please note that the guarantee, and Service availability, only apply to the UK and Republic of Ireland.

Before using the appliance for the first time, remove any protective polythene film and wash the oven shelves in hot soapy water to remove their protective covering of oil. Even so, when you first switch on the oven or grill you may notice a smell and some smoke.

Gas & Electrical connection

Please refer to installation instructions for the Gas & Electrical Safety Regulations and the Ventilation Requirements.

In your own interest, and that of safety, it is the law that all gas appliances be installed by a competent person who will ensure that the installation is in accordance with "The Gas Safety (Installation & Use) Regulations", & the "The Gas Safety (Installation & Use) (Amendment) Regulations". Failure to comply with these Regulations is a criminal offence.

Corgi registered installers undertake to work to satisfactory standards.

Disconnection of gas and electric appliances should always be carried out by competent persons.

Warning: This appliance must be earthed.

In the event of a power cut

1. Switch off the electricity to the appliance at the socket.
2. When the power returns, see the 'Programmer / Clock' section to 'Set the time of day'.

Introduction

The cooling fan

The cooling fan helps to keep the exterior cool during normal use. When a burner is operated, you should hear the cooling fan switch on automatically and be able to feel air evacuating from the appliance vents just below the fascia. The cooling fan will continue to operate for approximately 10 minutes after turning off the burners. This is normal. If there is no such indication that the fan is operating, the appliance will require servicing. **DO NOT USE THE APPLIANCE UNTIL IT HAS BEEN SERVICED.** Switch the appliance off at the mains and contact Customer Support.

For your safety

This appliance has a built in safety device to isolate the gas and electric supplies to various components in the event of fan failure.

If the programmer/clock and lights do not function, and the ignition system stops working, the safety device has operated. Within an hour, the safety device will reset itself and the programmer /clock display will flash.

To reset the programmer/clock, press the Plus and Minus buttons together for a few seconds. When the '●' is flashing in between the hour and minutes on the LED, reset the time of day.

If when a burner control is turned on, the fan does not operate in the normal way, then the appliance will require servicing. **DO NOT USE THE APPLIANCE UNTIL IT HAS BEEN SERVICED.** Switch the appliance off at the mains and contact Customer Support.

Continued use of the appliance without it being serviced could result in excessive temperatures being generated, which in turn could reduce the life of certain components.

Ventilation

The use of a gas cooking appliance results in the production of heat and moisture in the room in which it is installed. Ensure that the kitchen is well ventilated; keep natural ventilation holes open or install a mechanical ventilation device (mechanical ventilator).

Prolonged intensive use of the appliance may call for additional ventilation, for example opening a window, or more effective ventilation, for example increasing the level of mechanical ventilation where present.

This appliance is not connected to a combustion products evacuation device. It must be installed and connected in accordance with current installation regulations. Particular attention must be given to the relevant regulations regarding ventilation.

Introduction

Glass door panels

To meet the relevant Standards of Domestic cooking appliances, all the glass panels on this appliance are toughened to meet the fragmentation requirements of BS3193. This ensures that, in the unlikely event that a panel breaks, it does so into small fragments to minimise the risk of injury.

Please take care when handling, using or cleaning all glass panels as any damage to the surfaces or edges may result in the glass breaking without warning or apparent cause at a later date. Should any glass panel be damaged, we strongly recommend that it is replaced immediately.

The Gas Consumer Council (GCC) is an independent organisation which protects the interests of gas users. If you need advice, you will find the telephone number in your local telephone directory under Gas.

Condensation

When hot and cold air meet, condensation forms. The outer door is air cooled and the inner door gets hot, so some condensation might form; this is normal and will disappear within 10 - 15 minutes.

To replace a light bulb (if fitted)

Caution: Switch off the electricity supply to the cooker at the socket, to avoid the risk of electric shock.

Wait until the oven is cool, then remove the oven shelves.

Grasp the lens cover on the light fitting and pull it away from the side of the oven. Unscrew the bulb.

Please note that the oven light bulb is not covered by the guarantee. Replacement bulbs can be ordered from your local supplier, or bought from a hardware store.

Environmental Protection

We are committed to protecting the environment and operate an Environmental Management System which complies with BS EN ISO 14001.

Disposal of packaging

- All our packaging materials are recyclable and environmentally friendly.
- Please help us to protect our environment by disposing of all packaging in an environmentally friendly manner.
- Please contact your local authority for the nearest recycling centre.

Caution: Packaging materials can pose a risk of suffocation - keep away from children.

Be Safe - Not Sorry

When you are cooking, keep children away from the vicinity of the appliance.

This product is designed as a domestic cooking appliance for the preparation and cooking of domestic food products, and should not be used for any other purpose.

- Remove all packaging from the appliance before using for the first time.
- Make sure you read and understand the instructions before using the appliance.
- Keep electrical leads short so they do not drape over the appliance or the edge of the worktop.
- Keep all flammable materials (such as curtains, furnishings & clothing) away from the appliance.
- Parts of the appliance may be hot during or immediately after use. Allow sufficient time for the appliance to cool after switching off.
- Do not drape tea towels over the flue vents or doors, as this creates a fire hazard.
- Do not use aluminium foil to cover the grill pan, or put items wrapped in foil under the grill, as this creates a fire hazard.
- Never use the appliance for heating a room.
- Do not use the oven with the door inner glass panel removed (glass oven doors only).

- Use oven gloves when removing hot food / dishes from the oven or grill. The oven / grill and utensils will be very hot when in use.
- When opening the appliance door, take care to avoid skin contact with any steam which may escape from the cooking.
- Do not use foil on oven shelves or allow it to block the oven flue, as this creates a fire hazard, and prevents heat circulation.
- When cooking heavy items - eg; turkeys - do not pull the oven shelf out with the item still on the shelf.
- Switch off the electricity supply before replacing the oven light bulb, to avoid the risk of electric shock.
- All installation, servicing and maintenance work must be carried out by a competent person who will comply with current Regulations, Standards and Requirements.
- **Warning:** This appliance must be earthed.
- **When you have finished cooking check that all controls are in the off position.**
- As with all gas appliances, it is recommended that your appliance is serviced regularly.

Using the Grill

Caution: Accessible parts may be hot when the grill is used, young children should be kept away.

Grill ignition

Important: The door must be fully open when the grill is used.

Open the grill door.

Push in and turn the grill control knob clockwise to the grill position. Ensure that the grill burner is alight before leaving unattended

To switch off, turn the control knob clockwise to return it to the "●" off position.

If for any reason the burner fails to ignite, turn off the control and wait at least one minute before repeating the ignition procedure.

Preheating

Always preheat the grill for a few minutes for best results.

Aluminium foil

Never cover the grill pan or grill trivet with cooking foil, or allow fat to build up in the grill pan, as this creates a fire hazard.

Detachable grill pan handle

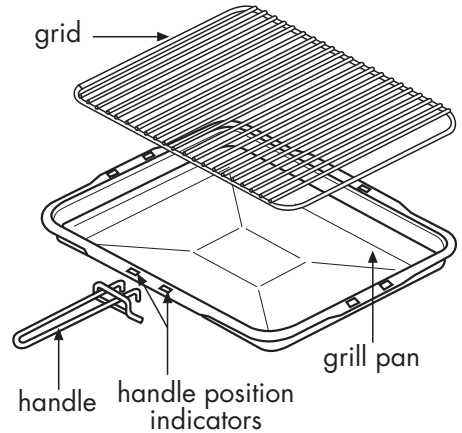

Place the handle over the edge of the grill pan, at the narrow side edges. Slide the handle to the centre, and locate between the handle position indicators.

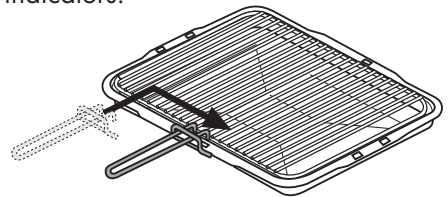

The handle should be removed from the pan during grilling, to prevent overheating.

The handle is designed for removing / inserting the grill pan under the grill when grilling.

If cleaning the grill pan when it is hot, use oven gloves to move it. *Do not* use the handle to pour hot fats from the grill pan.

Food for grilling should be positioned centrally on the trivet.

Using the Grill

Using the grill

Push the grill pan towards the back of the shelf, to position it under the grill.

Variation in grilling can be achieved by moving the grill pan up or down.

Important: Never operate the grill between the large flame and the off position.

The speed of grilling can also be controlled by selecting a higher or lower shelf position.

Always use the top shelf position for fast toasting.

For toasting, and for grilling foods such as bacon, sausages or steaks, use a higher shelf position.

For thicker foods such as chops or chicken joint pieces, use a middle to low shelf position.

The grill trivet, inside the grill pan, can be inverted to give a high or low position, or it may be removed.

When you have finished grilling, check that the control knob is returned to the off position.

Using the Ovens

When you are cooking, keep children away from the vicinity of the oven.

Notes

In the event of the flame being accidentally extinguished, the flame will automatically relight, owing to the automatic re-ignition system.

If it is found over a period of time that the oven becomes hotter when used at a particular gas mark, the thermostat may need to be replaced.

As part of the cooking process, hot air is expelled through a vent at the top of the oven(s). When opening the oven door, care should be taken to avoid any possible contact with potentially hot air, since this may cause discomfort to people with sensitive skin. We recommend that you hold the underneath of the oven door handle.

Oven furniture

Baking tray and roasting tins

For best cooked results and even browning, the maximum size baking trays and roasting tins that should be used are as follows;

Baking tray 350mm x 280mm

This size of baking tray will hold up to 16 small cakes.

Roasting tin 370mm x 320mm

We recommend that you use good quality cookware. Poor quality trays and tins may warp when heated, leading to uneven baking results.

Oven shelves

The oven shelf must be positioned with the upstand at the rear of the oven and facing upwards.

Extra shelves may be ordered from the Customer Care Centre.

You will see that there are differences between the oven shelves for the top oven and the main oven.

The top oven shelf helps to ensure even baking in the top oven. It has a rear deflector fitted to it, and is **not** intended for use in the main oven.

Preheating

The oven must be preheated for 15 minutes when reheating frozen or chilled food, and we recommend preheating for yeast mixtures, batters, soufflés and whisked sponges.

If you are not preheating the oven, the cooking times in the Baking Guide may need to be extended, as they are based on a preheated oven.

Oven lights & replacing bulbs

There are 4 oven lights, 2 in each cavity.

Caution: Switch off the electricity supply to the cooker at the socket, to avoid the risk of electric shock.

Wait until the oven is cool, then remove the oven shelves.

Grasp the lens cover on the light fitting and pull it away from the side of the oven. Unscrew the bulb.

Using the Ovens

Using the top oven

The top oven can be used in the same way as the main oven to cook a full range of dishes, however it is a secondary oven and there are some differences.

The top oven cavity is smaller in size and therefore better suited to smaller dishes and food portions. Please do not over load the oven or use cookware which is too large. Foods which rise will get better results when cooked in the main oven as will large dishes and joints of meat.

Ignition top oven

Push in and turn the top oven control knob anticlockwise to the full on position - Gas Mark 9. The oven burner, ignition, lights and cooling fan will operate automatically. Adjust the control knob to the Gas Mark required.

It can take 60 seconds for the burner to come on to the full rate.

Should the top oven burner be accidentally extinguished, it will automatically re-light.

To switch the top oven off, push in the control knob and turn it clockwise to the off position.

Preheating

Most cooking times given in recipes, or on convenience foods are based on a preheated oven.

Always preheat the top oven for at least 15 minutes if it is being used on its own. This will give the oven chance to maintain its optimum temperature.

To achieve the best results when cooking items which are chilled, frozen, yeast based, batters, souffles or sponges the oven must be preheated.

If the oven is not preheated before use, cooking times will need to be extended.

Zones of heat - top oven

Unlike the main oven, the temperature at the top of the top oven corresponds with the Gas mark selected, and it is slightly cooler towards the bottom of the oven.

Using the Ovens

Top oven baking guide

Dish	Recommended gas mark	Suggested shelf position	Approximate cooking time (preheated oven)
Scones	7	3	10 - 15 mins
Meringues	"S" slow setting	5	2 - 3 hours
Cakes			
Small cakes	5	3	15 - 25 mins
Whisked sponge	5	3	20 - 30 mins
Swiss roll	6	3	10 - 12 mins
Victoria sandwich (2 x 180mm / 7" per shelf)	4	3 (side by side)	20 - 35 mins
Genoese sponge (2 x 180mm / 7" per shelf)	5	3	25 - 30 mins
Pastry			
Rough Puff	7	3	cooking time depends on recipe & type of filling
Flaky / Puff	6	3	
Shortcrust	6	3	
Flan	6	3	
Biscuits			
Shortbread fingers	5	3	20 - 30 mins
Nut brownies	5	3	25 - 35 mins
Brandy snaps	4	3	10 - 15 mins
Flapjacks	4	3	25 - 40 mins
Ginger nuts	5	3	15 - 20 mins

Please note that the cooking times given in the baking guide are based on a pre-heated oven. The shelf positions are counted from the top of the oven downwards.

Using the Ovens

When you are cooking, keep children away from the vicinity of the oven.

Using the Main Oven

Ignition main oven

Push in and turn the main oven control knob anticlockwise to the full on position - Gas Mark 9. The oven burner, ignition, lights and cooling fan will operate automatically. Adjust the control knob to the Gas Mark required.

It can take 60 seconds for the burner to come on to the full rate.

Should the oven burner be accidentally extinguished, it will automatically re-light.

To switch the oven off, push in the control knob and turn it clockwise to the off position.

Pre-heating

Most cooking times given in recipes, or on convenience foods are based on a preheated oven.

Always preheat the main oven for at least 15 minutes. This will give the oven chance to maintain its optimum temperature.

To achieve the best results when cooking items which are chilled, frozen, yeast based, batters, souffles or sponges the oven must be preheated.

If the oven is not preheated before use, cooking times will need to be extended.

Zones of heat - main oven

The temperature at the centre of the oven corresponds with the selected gas mark and is slightly higher towards the top of the oven and slightly lower towards the oven base.

These zones of heat can be useful as different dishes requiring different temperatures may be cooked at the same time - eg; the temperature at the oven base is suitable for cooking baked vegetables, baked fruit, milk pudding, etc, and for warming bread rolls, soup, coffee, or ovenproof plates and dishes.

Baking guide - hints

To protect a very rich fruit cake during cooking, stand the tin larger tin or tie 2 layers of brown paper around the tin.

Cooking times for pastry dishes depend on the size and type of cooking dish and also the filling.

When cooking 2 trays of items, remove the top item when it is cooked and raise the lower item to the higher shelf to finish cooking, or where additional browning of the base is required - eg; pies and pastries - interchange part way through cooking.

Using the Ovens

Main oven baking guide

Dish	Recommended gas mark	Shelf position	Approximate cooking times
Scones	7	top to middle	8 - 15 mins
Meringues	"S" slow setting	middle to bottom	2 - 3 hours
Cakes			
Small cakes	5	middle to top	15 - 25 mins
Whisked sponge	5	middle to top	20 - 25 mins
Swiss roll	6	middle to top	10 - 12 mins
Victoria sandwich (2 x 180mm / 7")	4	middle to top	20 - 30 mins
Genoise sponge	4	middle	20 - 30 mins
Madeira (180mm / 7")	3	middle to top	1 - 1½ hours
Gingerbread	3	middle to top	1 - 1½ hours
Semi rich fruit cake (205mm / 8")	2 or 3	middle to top	2½ - 3 hours
Christmas cake	1 or 2	middle to bottom	depending on recipe
Dundee cake (205mm/8")	3	middle to bottom	2 - 2½ hours
Pastry			
Flaky / Puff	7	middle to top	15 - 45 mins
Shortcrust	6	middle to top	15 - 45 mins
Choux	6	middle to top	15 - 45 mins
Plate tarts	6	middle to top	30 - 45 mins
Biscuits			
Nut brownies	6	middle to bottom	15 - 20 mins
Brandy snaps	4	middle to top	7 - 18 mins
Flapjacks	4	middle to top	20 - 40 mins
Ginger nuts	4	middle to top	10 - 20 mins
Puddings (1 / 2 pint dish)			
Rice pudding	2	middle to top	2 - 2½ hours
Baked custard	3	middle to top	1 - 1½ hours
Bread and butter	3	middle to top	¾ - 1¼ hours
Hot soufflé	4	middle to top	35 - 50 mins
Fruit crumble	6	middle to top	½ - 1 hours

Using the Ovens

Roasting guide

The times given in the roasting guide are only approximate, because the size and age of the bird will influence cooking times as will the shape of a joint and the proportion of the bone.

Frozen meat should be thoroughly thawed before cooking. For large joints it is advisable to thaw overnight.

Frozen poultry should be thoroughly thawed before cooking. The time required depends on the size of the bird - eg; a large turkey may take up to 48 hours to thaw.

Use of a trivet with a roasting tin will reduce fat splashing and will help to keep the oven interior clean. Alternatively, to help reduce fat splashing, potatoes or other vegetables can be roasted around the meat / poultry.

Notes;

- When cooking stuffed meat or poultry, calculate the cooking time from the total weight of the meat plus the stuffing.
- For joints cooked in foil or covered roasters, and for lidded casseroles, add 5 minutes per 450g (1 lb) to the calculated cooking time.
- Smaller joints weighing less than 1.25kg (2½lb) may require 5 minutes per 450g (1lb) extra cooking time.
- Position the oven shelf so that the meat or poultry will be in the centre of the oven.
- It is recommended that the appliance is cleaned after open roasting.

Cook in oven at Gas Mark 5		Approximate cooking time (Preheated oven)
Beef	Rare Medium Well done	20 minutes per 450g (1lb), plus 20 minutes 25 minutes per 450g (1lb), plus 20 minutes 30 minutes per 450g (1lb), plus 30 minutes
Lamb	Medium Well done	25 minutes per 450g (1lb), plus 25 minutes 30 minutes per 450g (1lb), plus 30 minutes
Pork		35 minutes per 450g (1lb), plus 35 minutes
Poultry		20 minutes per 450g (1lb), plus 20 minutes

Using the Ovens

Roast turkey

Roasting turkey perfectly involves cooking two different types of meat - the delicate light breast meat, which must not be allowed to dry out, and the darker leg meat, which takes longer to cook.

The turkey must be roasted long enough for the legs to cook, so frequent basting is necessary. The breast meat can be covered once browned.

- Turkey should be roasted at gas mark 4 for 20 minutes per 1lb, plus 20 minutes unless packaging advises otherwise.
- The turkey can be open roasted, breast side down, for half of the cook time, and then turned over for the remainder of the cooking time.
- If the turkey is stuffed, add 5 minutes per lb to the cooking time.
- If roasting turkey covered with foil, add 5 minutes per 1lb to the cooking time.

To test if the turkey is cooked, push a fine skewer into the thickest part of the thigh. If the juices run clear, the turkey is cooked. If the juices are still pink, the turkey will need longer cooking.

Traditional fruit cakes

It should be remembered that ovens can vary over time, therefore cooking times can vary, making it difficult to be precise when baking fruit cakes.

It is necessary, therefore, to test the cake before removal from the oven. Use a fine warmed skewer inserted into the centre of the cake. If the skewer comes out clean, then the cake is cooked.

- Do not attempt to make Christmas cakes larger than the oven can cope with; you should allow at least 25mm (1 inch) space between the oven walls and the tin.
- Always follow the temperatures recommended in the recipe.
- To protect a very rich fruit cake during cooking, tie 2 layers of brown paper around the tin.
- We recommend that the cake tin is not stood on layers of brown paper, as this can hinder effective circulation of air.
- Do not use soft tub margarine for rich fruit cakes unless specified in the recipe.
- Always use the correct size and shape of tin for the recipe quantities.

Using the Ovens

Cooking frozen & chilled foods

- Preheat the oven.
- When cooking frozen or chilled foods, please follow the manufacturer's instructions. If cooking more than one tray or item, cooking times may need to be increased.
- Please ensure that foods are piping hot before consumption.
- Always use the temperature setting stated on food packaging when cooking convenience food.
- Never overload the tray - eg; oven chips should be placed onto the baking tray in one even layer for satisfactory cooking.
- Follow the cooking times given on packaging but remember they are only intended as a guide and do not take individual preferences into account.
- Always cook frozen convenience foods straight from the freezer unless packaging advises otherwise.

Slow cooking

- Make sure that frozen foods are thoroughly thawed before cooking.
- Do not slow cook joints of meat or poultry weighing more than 2½kg / 4½lb.
- For roasting joints of meat or poultry and for pot roasts preheat the oven to gas mark 6 and cook for 30 minutes, then adjust the oven control to '**S**' slow set for the remainder of the cooking time.
- Always use the top half of the oven when slow cooking.
- Slow cooking times will be about three times as long as conventional cooking times.

Using the Ovens

Automatic cooking

The automatic cooking facility is controlled by the programmer (see 'Programmer/ Clock' section) and allows complete meals, or individual dishes to be cooked while you are out of the house, to be ready for when you return. The 'Ready Time' should be set as close as possible to, or just after your anticipated return so food is not left standing in a warm oven.

Do:

- Select foods which are as fresh as possible, and as cold as possible - ie; preferably straight from the refrigerator.
- Choose foods which are suitable for cooking from a cold start, as some dishes will be affected by being left uncooked, at room temperature, perhaps for several hours - eg; a wet filling on a pastry base.
- Make sure that meat and poultry are thoroughly thawed (but still cold from the refrigerator), before placing them in the oven, and avoid using rolled joints of meat which can be more susceptible to the growth of food poisoning organisms.
- Cover dishes with lids or foil to keep the food moist, prevent the transfer of odours, and protect from possible contamination; the food can be uncovered towards the end of cooking to crisp and brown.

Do not:

- Warm food should never be placed in the oven if there is a delay period. Stews prepared by frying the meat and vegetables first should be cooked as soon as possible, or refrigerated prior to placing in the oven.
- Some dishes are not suitable for cooking on automatic - eg; dishes containing left over cooked meat or poultry, eggs, cooked rice or seafood.
- Do not put food items (intended for automatic cooking) into a warm oven. Allow the oven to cool before setting for automatic cooking.
- Do not over-fill dishes containing liquids as they might boil over.
- Never leave food in the oven to cool slowly after cooking; serve immediately or refrigerated.
- Never use the automatic facility to reheat 'cook chill' foods as they should go straight from the refrigerator into a preheated oven.

Using the Ovens

Important: Food is more susceptible to the growth of food poisoning organisms in warm conditions. If the weather is hot, either take care to ensure that food is not left standing in a warm oven, or avoid using the automatic cooking facility.

Hints for automatic cooking

- Food is placed in a cold oven so you will need to add about 10 - 15 minutes onto the cooking time to allow for the oven to reach the selected temperature.
- Wine or beer may ferment, and cream may curdle during the delay period, so it is best to add these ingredients just before serving.
- Potatoes should be parboiled or brushed with oil to prevent discolouration during the delay period.
- Meat can be brushed with oil to prevent it drying.
- Lemon juice can be added to certain fruits and vegetables such as apples, pears, turnips and parsnips to prevent discolouration during the delay period.

Programmer / Clock

The programmer buttons

- minus
- + plus

The 'function' button in the centre is used for setting the minute minder and setting up the automatic cooking. See below for details.

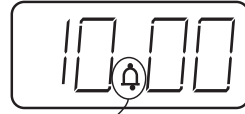
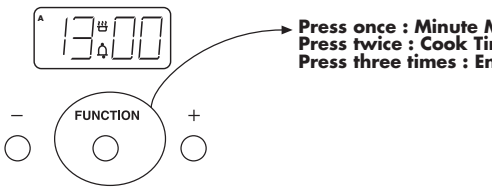

Minute Minder symbol

This Bell symbol appears when the Minute Minder function has been selected. While the Minute Minder is being set, the Bell symbol flashes. Once the length of time is set, the Bell symbol remains lit until the time runs down, or the function is cancelled.



This message and 'A' symbol appear when you are asked to set the length of time you require the oven to cook automatically for. Using the Plus and Minus buttons adjusts this accordingly.

Symbols on the LED display.

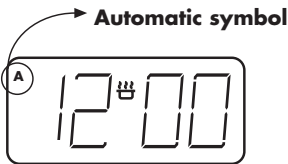

This 'A' symbol appears when either a semi, or fully automatic program is selected. This symbol will flash while a program is being set. Once a program is set the symbol will light up, and remain lit until the alarm sounds, or the program is cancelled



This message and 'A' symbol appear when you are asked to enter in an end time, or when you would like the oven to switch itself off.

Programmer / Clock

To set the time of day

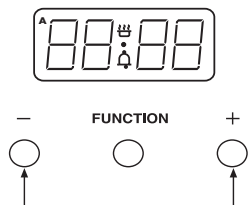

- ◆ Press the Plus and Minus buttons together for a few seconds and release.
- ◆ Set the time of day using the Plus and Minus buttons. Press once for single digit increase, press and hold for rapid increase..
- ◆ Once the time of day has been set wait approx 10 seconds until the '●' stops flashing.
- ◆ Use the appliance as normal.

To select an alarm tone

There are three tones to chose from.

- ◆ Press the *minus* button to listen to the first tone.
- ◆ Release the *minus* button and press it again to listen to the second tone etc.
- ◆ Releasing the *minus* button after the tone has sounded will automatically select that tone

Setting the minute minder

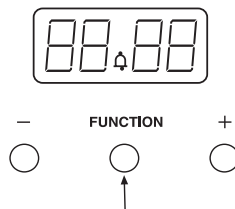

- ◆ To set the Minute Minder, press the Function button once. The bell symbol will appear and start flashing. The flashing only lasts for 5 seconds so the time must be set within this time frame.
- ◆ Use the Plus and Minus button to set the length of time required. Once this has been done, the Minute Minder is set.
- ◆ When the desired length of time has counted down the alarm will sound.
- ◆ To cancel the tone, press any of the buttons.
- ◆ To cancel the Minute Minder at any time, press the Plus and Minus buttons together.

Programmer / Clock

Semi-automatic cooking

There are two types of semi automatic cooking available on this appliance.

The oven must be switched on, and in use to use either of these functions successfully.

The Duration method allows you to set the oven for a specific length of time. If a dish needs 2 hours to cook, then it is possible for you to set the oven to turn off 2 hours later. This allows you to be sure that your food will be cooked for a set length of time and no longer.

The End Time method allows you to enter a specific time when you would like the oven to switch off. If you wish to leave the oven unattended, then it offers peace of mind that the oven will have turned itself off at the time set.

However, once the program is set then it cannot be adjusted. Extra time cannot be added, nor can the end time be extended.

To cancel the semi automatic programs, press both the Plus and Minus buttons together. This can be done at any time during the cooking process. Then if necessary, re program.

For the instructions on how to use both of these functions, please see the following page.

Fully automatic cooking

This function incorporates both a duration and an end time and is meant to be used when you wish to delay the start time.

We recommend that the first few times this function is used you are in the house, this will familiarise you with your oven and prevents food from being over cooked or under cooked.

Care must be taken when selecting foods for this function, it is not recommended for certain food items which may spoil, or are sensitive to being left.

It is also advisable to set the end time to be as close to your return as possible to prevent food being left standing.

Programmer / Clock

Semi-automatic cooking

The Duration method

◆ Press the Function button twice, **(1)** which will skip past the Minute Minder.

◆ The LED display will flash the word 'dur', **(2)** and the 'A' will flash on the left hand side of the display.

◆ Use the Plus and Minus buttons to set the length of time you want to cook for. **(3)** This must be done within 5 seconds or the time of day will show again.

Once this is done the oven will automatically switch off once the time has elapsed, and the alarm will sound.

To switch off the alarm, press any button. To view any remaining time press the function button twice

The End Time method

◆ Press the Function button three times, which will skip past the Minute Minder and the Duration programmer. **(4)**

◆ The LED display will flash the word 'End' and the 'A' will flash on the left hand side of the display. **(5)**

◆ Use the Plus and Minus buttons to select the time the oven is required to turn off. **(6)**

Once this is done the oven will turn itself off at the time you have selected. To switch off the alarm, press any button.

1. The Duration method

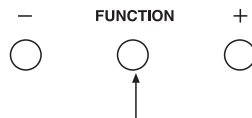

2.



3.

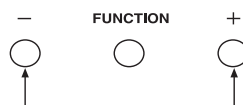
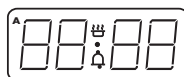

4. The End Time method

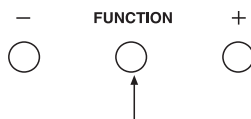

5.



6.

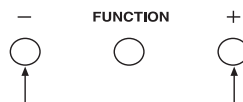
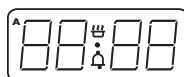

Programmer / Clock

Fully automatic cooking (example)

This programming method is best suited for when a delayed start time is required. Unlike the semi automatic methods this requires both the duration and the end time to be entered. The timer will work out the start time and begin cooking.

◆ Press the function button twice to select the length of time your food will need. **(7)**

◆ The 'A' on the left hand side will flash and the 'dur' message will flash up. **(8)**

◆ Using the Plus and Minus buttons set the time you require within 5 seconds of the 'dur' message. **(9)**

◆ Press the function button three times until the 'A' flashes again and the 'End' messages appears. **(10) & (11)**

◆ Using the Plus and Minus buttons, set the time you would like the oven to switch off. **(12)**

◆ Set the temperature of the oven and place the food inside.

While the automatic function is running, the 'A' will appear statically on the display, with the time.

Try to keep the end time as close to when you expect to return, this will prevent cooked food from being left standing in a warm oven.

The timer will calculate the appropriate start time.

7

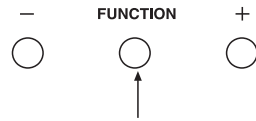

8



9

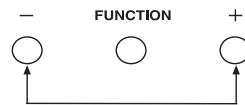
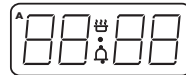

10

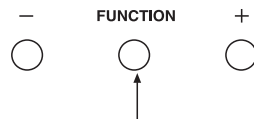

11



12

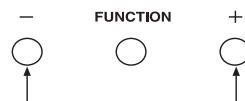

Automatic cooking - hints

Automatic cooking

These notes below are to help you with using the automatic cooking facility. Please make sure that you read them carefully before you start using the automatic functions.

Do

- Familiarise yourself with the use of the programmer.
- Select foods which are as fresh as possible, and as cold as possible - ie; preferably straight from the refrigerator.
- Choose foods which are suitable for cooking from a cold start, as some dishes will be affected by being left uncooked, at room temperature, perhaps for several hours, especially when the weather is hot.
- Make sure that meat, poultry and uncooked food are thoroughly thawed before placing them in the oven.
- Cover dishes with lids or foil, as they may be left standing in the oven for some time before cooking.

Do not

- Never place warm food in the oven for delayed cooking - eg; stews prepared by frying meat first must be thoroughly cooled before placing in the oven.
- Do not cook dishes containing left over cooked meat or poultry, or pastry dishes with wet fillings, as they are not suitable for automatic cooking.
- Do not put food items intended for delayed cooking into a warm oven - allow the oven to cool before setting for delayed cooking.
- Do not over-fill dishes containing liquids, as they might boil over.
- Never leave food in the oven to cool slowly after cooking, serve immediately or refrigerate.

Cleaning

Caution: Any cleaning agent used incorrectly may damage the appliance.

Always let the appliance cool before cleaning.

Some cooking operations generate a considerable amount of grease. This, combined with spillage, can become a hazard if allowed to accumulate on the appliance through lack of cleaning. In extreme cases this may amount to misuse of the appliance and could invalidate your guarantee.

It is recommended that the appliance is cleaned after open roasting.

Do not use caustic, corrosive or abrasive cleaning products, products containing bleach, coarse wire wool or any hard implements, as they will damage the surfaces.

All parts of the appliance can be safely cleaned with a cloth wrung out in hot soapy water.

Chrome plated parts

OVEN SHELVES & OVEN SHELF RUNNERS,
GRILL PAN TRIVET

Do not use abrasives or polishes. Use a moist soap pad.

Shelf runners can be removed for cleaning. Grasp the runners, and slide out of the hanging holes as shown.

Note: These items may also be cleaned in a dishwasher.

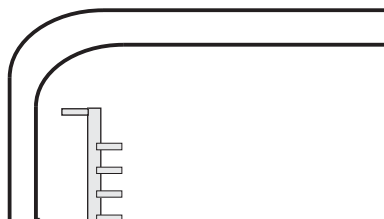

Enamel surfaces

OVEN CAVITIES, GRILL PAN & ROASTING TIN

If you do a lot of open roasting, or roast at temperatures above 180°C, we recommend regular cleaning. Use of a trivet in a roasting tin when roasting will help reduce fat splashing.

Caution: Most types of cleaning agent will damage these surfaces.

Only use a few drops of washing up liquid in hot water. Wipe the surfaces with a clean cloth wrung out in hot soapy water - if larger splashes of fat do not readily disappear, scrub the area with a nylon brush or nylon pan scourer and hot soapy water. Rinse well and heat the oven to dry the surfaces.

Cleaning

Glass parts

FACIA PANEL & DOOR PANELS

Use a mild cream cleaner.

Rinse thoroughly and dry with a soft cloth. Do not use abrasive cleaners or polishes.

To remove the glass panel for cleaning, open the door to the door stop position (about 30° open), hold the top and bottom edges of the panel and slide out. Note that if the door is opened fully when removing the inner door glass panel, the door may spring shut.

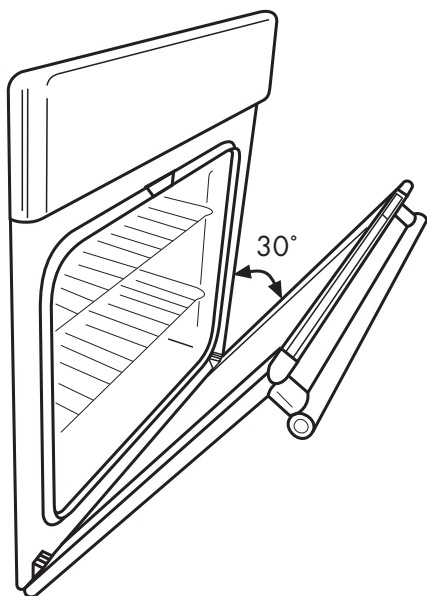

Door stop position

Important: if the inner door glass panel is removed for cleaning, it must be replaced the right way up as shown, and pushed fully in to the stop position.

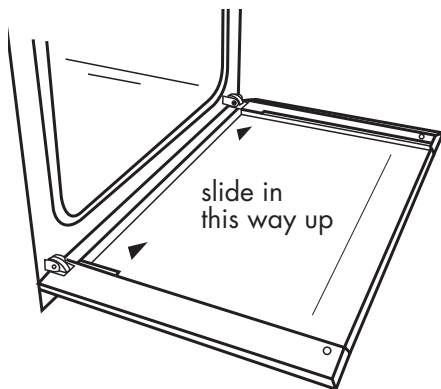

Painted, plastic and metal finish parts (if fitted)

OVEN DOOR FRAME, DOOR HANDLES, OUTER FRAME TRIM, CONTROL KNOBS

Only use a clean cloth wrung out in hot soapy water.

Cleaning

Stainless steel surfaces (stainless steel finish models only)

FACIA PANEL, HANDLES

Only use a clean cloth wrung out in hot soapy water, and dry with a soft cloth.

Stubborn marks can be removed using stainless steel cleaner. We recommend that you clean the whole of the stainless steel area to maintain a uniform finish. Supplies can be purchased from the Customer Care Centre.

Do not use undiluted bleach or any products containing chlorides as they can permanently damage the steel.

Extra care should be taken when cooking food in salted water. Some foods are corrosive - eg; vinegar, fruit juices and especially **salt** - they can mark or damage stainless steel if they are left on the surface. Turn off and wipe any spillage immediately, taking care to avoid skin contact with any hot surface or spillage.

Sharp objects can mark the surface of stainless steel, but marks will become less noticeable with time.

To maintain the finish of the stainless steel, or to remove any greasy marks, wipe the stainless steel surface sparingly with a *minimum* amount of baby oil and kitchen paper. Do not use cooking oils, as these may contain salt, which can damage the stainless steel surface.

Installation Instructions

Before you start: Please read the instructions. Planning your installation will save you time and effort.

Prior to installation, ensure that the local distribution conditions (nature of the gas and gas pressure) and the adjustment of the appliance are compatible. The adjustment conditions are stated on the data badge.

This appliance is not connected to a combustion evacuation device. It shall be installed and connected in accordance with current installation regulation. Particular attention shall be given to the relevant requirements regarding ventilation.

In your own interest and that of safety, it is the law that all gas appliances be installed and serviced by competent persons. CORGI registered installers undertake to work to satisfactory standards.

Where regulations or standards have been revised since this handbook was printed, always use the latest edition.

In the UK the regulations and standards are as follows:

1. Gas Safety Regulations (Installation and Use).
2. Building Regulations - Issued by the Department of the Environment.
3. Building Standards (Scotland) (Consolidated) - Issued by the Scottish Development Department.
4. The current I.E.E. Wiring Regulations.
5. Electricity at Work Regulations.
6. BS 6172 Installation of Domestic Gas cooking Appliances
7. Installation & Servicing Instructions for this appliance.

For installation in countries other than the UK, the appliance must be connected in

accordance with all local gas and electrical regulations. In the Republic of Ireland, Installers should refer to IS813 Domestic Gas Appliances.

Ventilation Requirements

The room containing the appliance should have an air supply in accordance with BS 5440: Part 2.

- All rooms require an openable window, or equivalent, and some rooms will require a permanent vent as well.
- For room volumes up to 5m³ an air vent of 100cm² is required.
- If the room has a door that opens directly to the outside, or the room exceeds 10m³, NO AIR VENT is required.
- For room volumes between 5m³ and 10m³ an air vent of 50cm² is required.
- If there are other fuel burning appliances in the same room, BS 5440: Part 2 should be consulted to determine the air vent requirements.
- This appliance must not be installed in a bed sitting room of less than 20m³ or in a bathroom or shower room.

Windows and permanent vents should therefore not be blocked or removed without first consulting a CORGI gas installer.

In the Republic of Ireland, refer to relevant Irish Standards for correct ventilation requirements.

Failure to install appliances correctly is dangerous and could lead to prosecution. This appliance is not connected to a combustion products evacuation device. It shall be installed and connected in accordance with current installation regulations. Particular attention shall be given to the relevant requirements regarding ventilation.

INSTALLATION INSTRUCTIONS

Step 1: Prepare installation

Do not lift the appliance by the door handle.

Remove the fixing screws from the polythene bag on the top of the appliance, but leave the appliance in the base tray packaging until you are ready to install it.

Whilst every care is taken to eliminate burrs and raw edges from this appliance, please take care when handling - we recommend the use of protective gloves during installation.

Please note that the weight of this appliance is approximately **48kg** (unpacked). Take care when lifting it into the housing unit - always use an appropriate method of lifting.

Note: When removing the appliance from the base tray packaging care should be taken to ensure the appliance is not damaged.

Siting the appliance

If this appliance is to be installed near to a corner where the adjacent cabinets run at right angles forward of the appliance, there must be a gap of at least 90mm between the appliance and the cabinets, to prevent overheating of the cabinets.

When installed in a typical 600mm deep built in housing unit, the false back should be removed from the housing unit, to provide the necessary depth for installation.

When the false back is removed, it is normally the case that the support shelf for the appliance leaves a gap between the back edge of the support shelf and the rear wall of approximately 80mm.

If no gap occurs between the back edge of the shelf and the wall behind the unit, you must create a gap of at least 30mm by shortening the shelf and any other shelf below the appliance.

Cut 12mm from the top of any plinth that may be fitted (see diagram).

Important: Do not modify the outer panels of this appliance in any way.

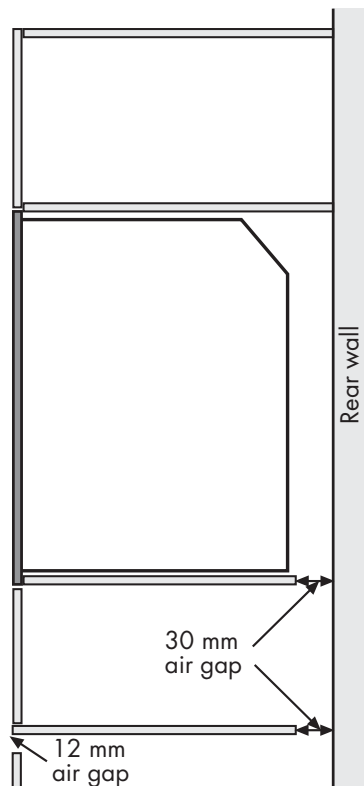

INSTALLATION INSTRUCTIONS

Dimensions

The appliance is designed to fit into a standard 600mm wide housing unit, with minimum internal dimensions as shown.

Note: All sizes are nominal, some variation is to be expected.

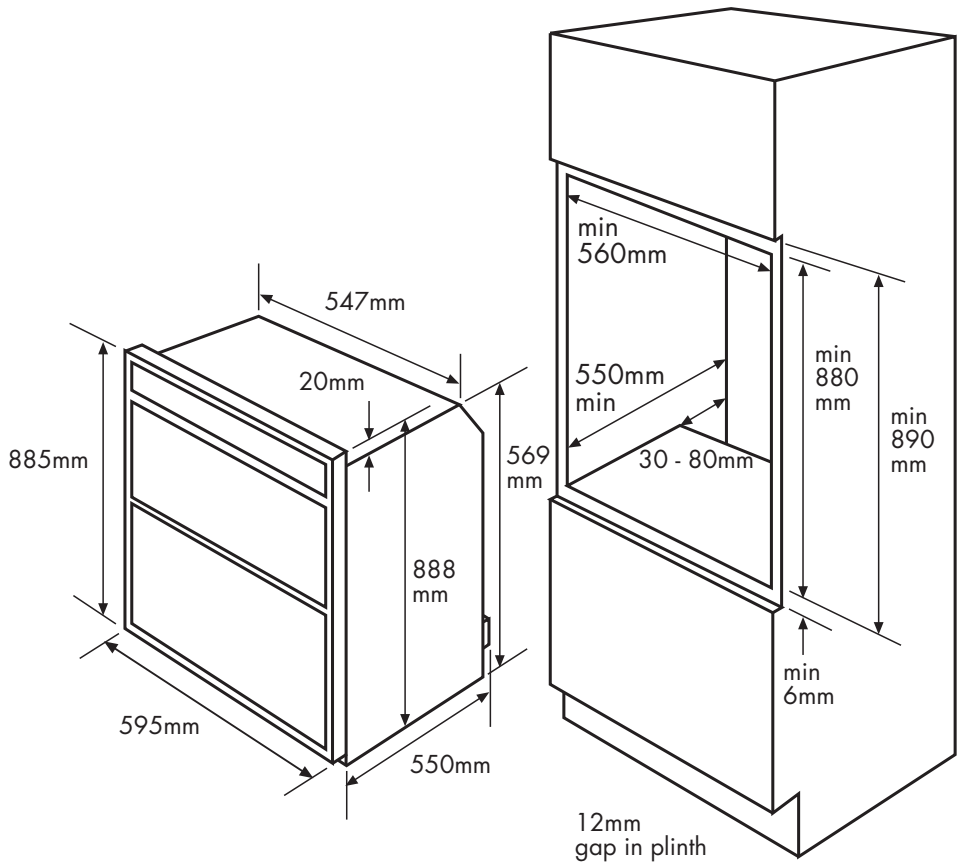

Installation Instructions

Step 2: Connect to the electricity supply

This appliance must be connected by a competent person, using fixed wiring via a double pole switched fused spur outlet, with a contact separation of 3mm at all poles.

Use a 3 amp fuse.

We recommend that the appliance is connected by a qualified electrician, who will comply with the I.E.E. and local regulations.

Warning: This appliance must be earthed.

The wires in the mains lead are coloured in accordance with the following code:

Green & Yellow = earth,

Blue = neutral,

Brown = live.

As the colours of the wires in the mains lead for the appliance may not correspond with the coloured markings identifying the terminals in your spur box, proceed as follows:

1. The wire which is coloured green and yellow must be connected to the terminal marked **E** (Earth)  or coloured green.
2. The wire which is coloured blue must be connected to the terminal marked **N** (Neutral) LOAD or coloured Black.
3. The wire which is coloured brown must be connected to the terminal marked **L** (Live) LOAD or coloured Red.

If the supply cord is damaged, obtain a special cord from the Customer Support Helpline, which must be fitted by a qualified person.

Typical example of a double pole fused spur outlet

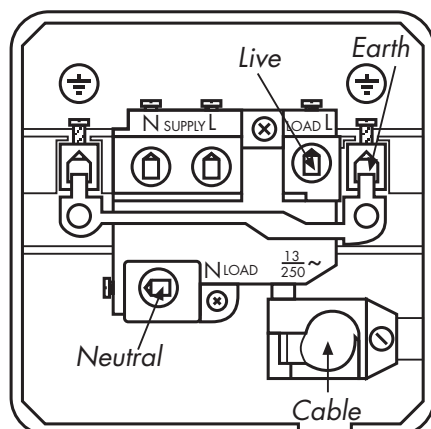
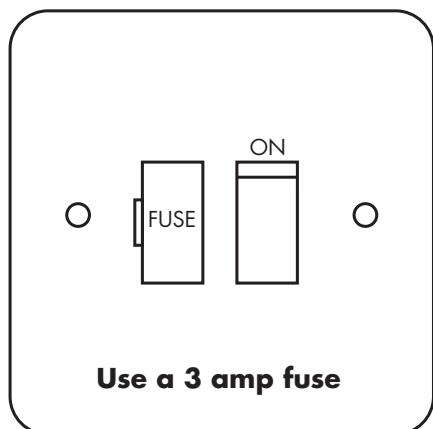

Installation Instructions

Step 3: Connect to gas supply

1. The inlet to the appliance is ISO 7 - Rp ½" internal thread situated towards the top right corner of the rear.
2. Fit the bayonet connection to the wall in the shaded area as shown. The shaded area shown is applicable to installations in minimum depth cabinets. If more room is available, the bayonet fixing area can be extended, provided that the flexible tube does not obscure the fan intake.

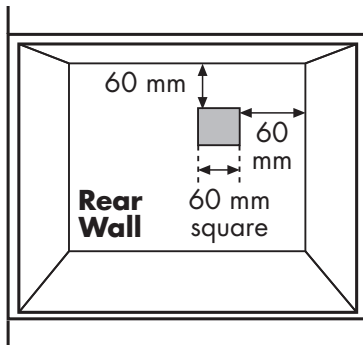

3. Use a 900mm - 1125mm length of flexible connector. The flexible connector shall be fitted such that it cannot come into contact with a moveable part of the housing unit (eg; drawer) and does not pass through any space susceptible of becoming congested. Make sure that the flexible connector does not block the cooling fan inlet.
4. Flexible connections should be to BS 669. Parts of the appliance likely to come into contact with a flexible connector have a temperature rise less than 70°C.
5. Rigid connections must be accessible to disconnect for servicing. Cut a 150mm square hole in the right hand rear corner of the support shelf for the supply pipe.
6. **Make sure all connections are gas sound.**

Installation Instructions

Step 4: Check edging strip

The edging strip is factory fitted to the front side edges of the appliance front frame. This strip provides the cabinetry with extra protection from any escape of heat.

When installing the product, ensure that the edging strip is correctly located on the outer edges of the front frame, before positioning and securing the appliance to the cabinet.

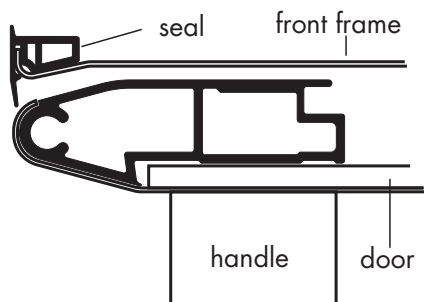

When securing the appliance, the fixing screws provided are driven through the edging strips into the cabinet - the seal will straighten up and sit flush to the cabinet when the screws are fully home.

Step 5: Secure appliance into housing unit

Insert appliance into cabinet.

Note: The unit housing the appliance must be appropriately fixed.

To secure appliance to housing unit

Note: Ensure that the appliance is centrally located.

Take care not to damage the appliance or cabinet.

There are 6 black no 8 x 25mm long chipboard screws for securing appliance to cabinet.

- Open the grill / top oven door, and screw 2 screws through the top corner holes in the front frame.
- With the grill / top oven door still open, screw 2 screws through the holes in the front frame, located under the grill compartment.
Close the grill / top oven door.
- Open the main oven door, and screw the remaining 2 screws through the bottom corner holes in the front frame.
Close the main oven door.

Installation Instructions

Step 6: Commissioning

Pressure test point

Use the oven burner. From inside the oven remove the burner cowl. Remove the small screw at the LHS of the burner cradle. Slide the burner to the left to access the injector. Connect manometer to the injector and turn the grill burner to full on to check pressure. Replace in reverse order.

Burner aeration

All burners have fixed aeration and no adjustment is possible.

Pressure setting

G20 Natural Gas @ 20 mbar

Electrical systems check

In the event of an electrical fault the preliminary electrical system check (earth continuity, short circuit, polarity and resistance to earth) must be carried out.

Ignition

The automatic ignition continues to spark for a short time after the burner has lit until the flame is established.

Ovens (Top and Main)

1. Push in and turn the control knob to Gas Mark 9. The oven burner/ignition/light/cooling fan will come on automatically.
2. Adjust to the required setting.
3. The burner may not come on to a full rate unless the oven door is closed.
The oven burner operates at a low rate for up to 60 seconds until the flame supervision device opens and full gas rate is obtained.

Grill

1. Open the door, push in and turn the control knob anticlockwise to the full on setting.
2. Check condition of flame.

When you first turn on the oven or grill you may notice a smell and some smoke which comes from the protective coating of oil burning off from some of the parts.

Before leaving the installation

Show the customer how to ignite the oven and grill, and give them this handbook. Thank you.

Technical Data

Data badge

Lower part of front frame and the rear panel of the appliance

Pressure setting

Natural Gas G20 @ 20 mbar (8"wg)

Gas category

Natural gas - I_{2H}

Appliance class

Class 3 double oven and grill

Ignition

Mains operated re-ignition generator

Oven light

4 x 25W

Electrical supply

220 - 240V ~ 50Hz, 137W

Grill

Nominal Rate Q _n	2.25kW
Injector	1.12mm
Spark gap	3 - 4mm

Oven

Bray type burner, sheet steel body, stainless steel flame strip

Nominal Rate Q _n	2.5kW
Injector	1.25mm
Spark gap	3 - 4mm
Thermostat	50

Oven injector - If the injector is removed or replaced for any reason, it is mandatory to apply Hylomar PL32 or Plasticol X10 sparingly to the thread prior to (re)fitting.

Top oven

Nominal rate Q _n	1.8kW
Injector	130 amal
Spark gap	3 - 4mm
Thermostat bypass	50

Oven injector - If the injector is removed or replaced for any reason, it is mandatory to apply Hylomar PL32 or Plasticol X10 sparingly to the thread prior to (re)fitting.

Maximum heat input Σ
 Σ Q_n 4.75kW

Countries of destination

GB - Great Britain

Stoves Customer Care

Please keep this handbook in a safe place as the information inside may be of use should you sell, or pass on the appliance. Please fill in the model number and serial number in the spaces provided below as they will assist us should you need to call.

0871 22 22 502

When you dial this number you will hear a recorded message and be given a number of options. This indicates that your call has been accepted and is being held in a queue. Calls are answered in strict rotation as our Customer Care Representatives become available.

Enter appliance numbers here for future reference:

Model No									
4	4	4							
Serial No									

These numbers can be found on your appliances data badge.
Outside the UK and Northern Ireland, refer to your local supplier.